

Part Number: PU060-12160-P1

Kit Contents

Item #	Quantity Req.	Description
1	1	Front Passenger Side Mudguard
2	1	Front Driver Side Mudguard
3	1	Rear Passenger Side Mudguard
4	1	Rear Driver Side Mudguard
5	1	Hardware Kit
6	1	Instruction Sheet (Electronic Copy)

Hardware Bag Contents

Item #	Quantity Req.	Description
Front (1 Bag)		
1	6	#14 x 19 mm Screw
2	2	Push Pin
Rear (1 Bag)		
3	2	Push Pins
4	2	M5 x 20mm Screw
5	4	M5 x 15 mm Screw
6	2	#14 x 19 mm Screw (Hex)
7	6	M5 Spring Clip

Additional Items Required For Installation

Item #	Quantity Req.	Description
1		
2		
3		

Conflicts

Ground effects

Recommended Tools

Personal & Vehicle Protection	Notes
None	
Special Tools	Notes
Installation Tools	Notes
Screwdriver	Phillips #2, #3, Slot
Drill/Angled Drill	
Drill Bit	6mm (1/4"), 8mm (5/16")
Socket Driver	10mm Socket
Clean Cloth/Rag	
Special Chemicals	Notes
Cleaner	Soap & water mixture

General Applicability

All models

Recommended Sequence of Application

Item #	Accessory
1	
2	
3	

*Mandatory

Vehicle Service Parts (may be required for reassembly)

Item #	Quantity Req.	Description
1		
2		
3		

Legend

 **STOP:** Damage to the vehicle may occur. Do not proceed until process has been complied with.

 **OPERATOR SAFETY:** Use caution to avoid risk of injury.

 **CAUTION:** A process that must be carefully observed in order to reduce the risk of damage to the accessory/vehicle and to ensure a quality installation.

 **TOOLS & EQUIPMENT:** Used in Figures calls out the specific tools and equipment recommended for this process.

 **REVISION MARK:** This mark highlights a change in installation with respect to previous issue.

 **SAFETY TORQUE:** This mark indicates that torque is related to safety.

Care must be taken when installing this accessory to ensure damage does not occur to the vehicle. The installation of this accessory should follow approved guidelines to ensure a quality installation.

These guidelines can be found in the "Accessory Installation Practices" document.

This document covers such items as:-

- Vehicle Protection (use of covers and blankets, cleaning chemicals, etc.).
- Safety (eye protection, rechecking torque procedure, etc.).
- Vehicle Disassembly/Reassembly (panel removal, part storage, etc.).
- Electrical Component Disassembly/Reassembly (battery disconnection, connector removal, etc.).

Please see your Toyota dealer for a copy of this document.

1. Clean the Front Mounting Area.

-  (a) Clean and degrease the front body panel where the mudguard is to be located with a clean cloth and soap/water mixture.

2. Remove the Front Hardware.

- (a) Remove and discard the existing screws at locations B and D (Fig. 2-1).

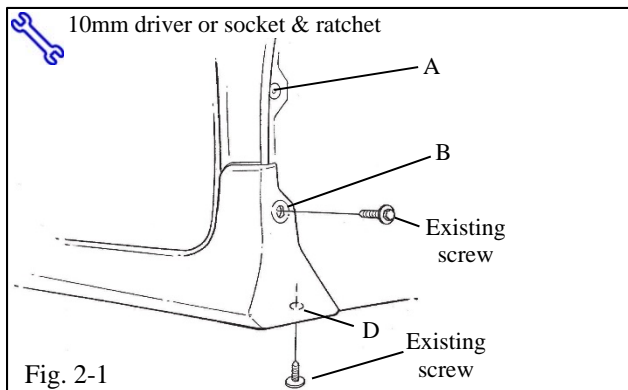

3. Install the Front Mudguard.

-  (a) While holding the part up and into body panel, mount the mudguard on the body panel and install the supplied screws in locations B and D, then tighten (Fig. 3-1). Do not overtighten the screws.

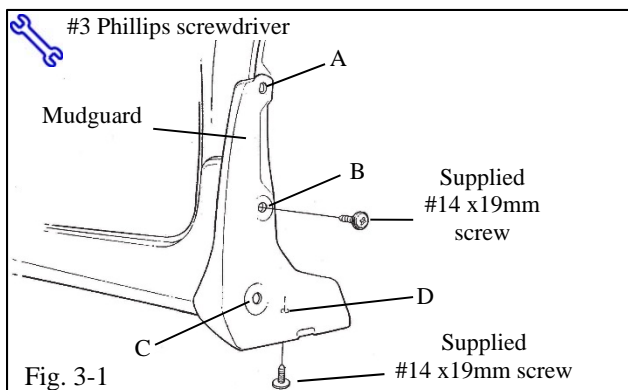

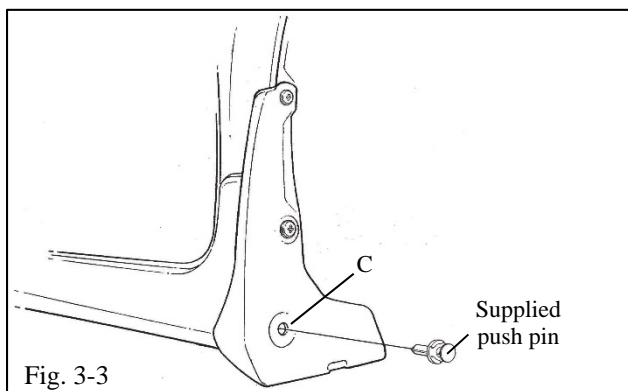
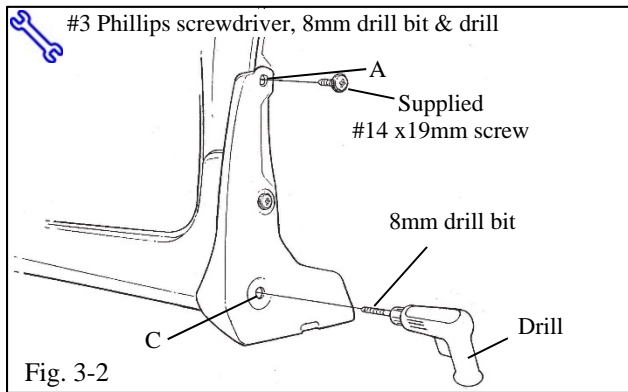

(b) Hold the part up and into body panel and install a supplied screw in location A (Fig. 3-2).

 (c) While holding the part firmly against panel, use the part as a template to drill an 8mm hole in location C (Fig. 3-2).

(d) Install a supplied push pin in location C (Fig. 3-3).

(e) Repeat Steps 1 through 3 on the other side.

4. Clean the Rear Mounting Area and Remove the Wheel.

 **NOTE: REMOVAL AND REINSTALLATION OF THE REAR WHEELS IS REQUIRED TO DRILL THE PANEL EDGE AND LINER ATTACHMENT HOLES.**

 (a) Clean and degrease the rear bumper panel where the mudguard is to be located with a clean cloth and soap/water mixture.

(b) Support vehicle and remove rear wheel. Follow the owner's manual procedure.

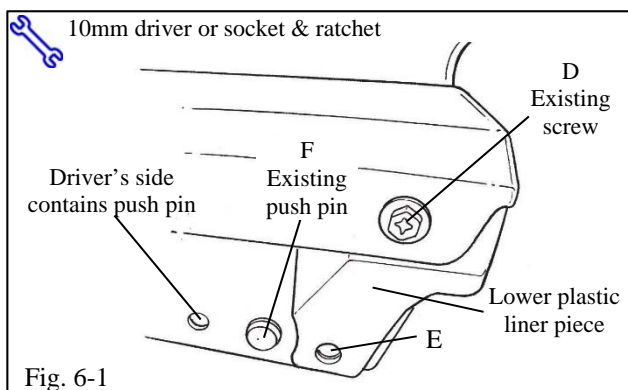
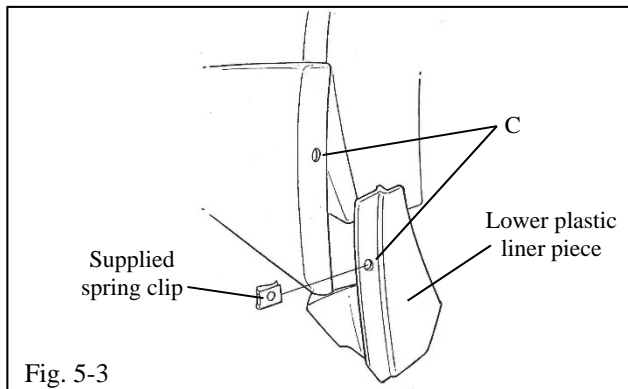
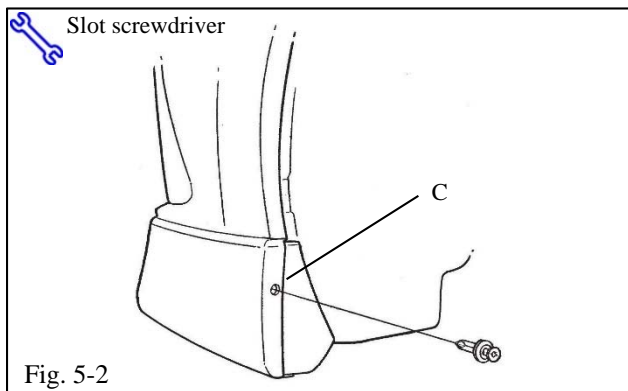
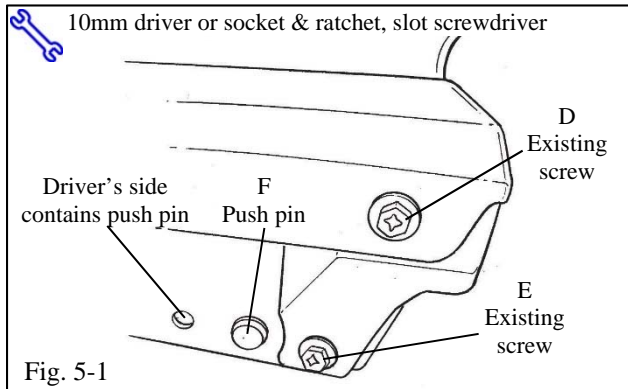

5. Remove and Install the Rear Hardware.

- (a) Remove and **RETAIN** the existing underside screw at location D. Remove and **DISCARD** the existing underside screw at location E (Fig. 5-1).
- (b) Remove and **RETAIN** the existing under side push pin at location F (Fig. 5-1).
- (c) Remove and discard the existing push pin at location C (Fig. 5-2).

- !** (d) Pull the cladding out and remove the lower plastic liner piece. Install a supplied spring clip over the hole location with the turned up edge on the inside of the panel (Fig. 5-3).

6. Install the Rear Mudguard.

- (a) Reinstall the lower plastic liner piece and reinstall the screw at location D. Reinstall the original push pin at location F (Fig. 6-1).

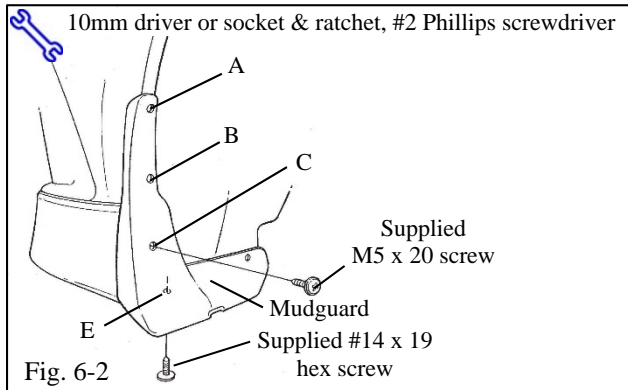

- (b) Hold the mudguard up and into the bumper panel and install a supplied M5 x 20mm screw in location C, then tighten (Fig. 6-2).
- (c) Hold the part up and into the bumper panel and install a supplied #14 x 19 hex screw in location E, then tighten (Fig. 6-2).

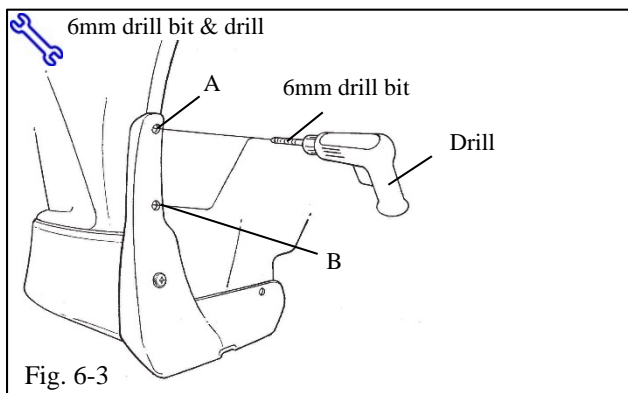

- ⚠ (d) While holding the liner and bumper panel tightly together, use the part as a template to drill 6mm holes at locations A and B (Fig. 6-3).

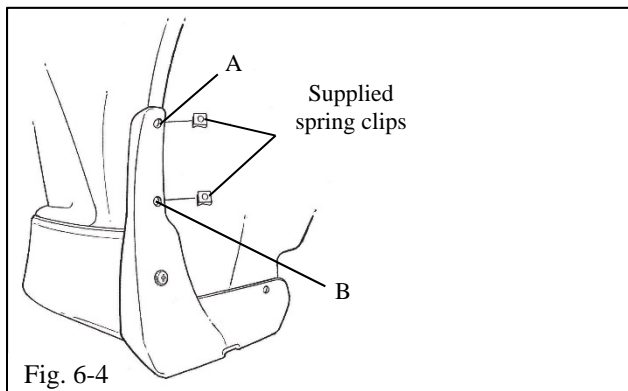

- (e) Pull the mudguard out slightly and install supplied spring clips over the drilled panel edge holes at locations A and B with the turned up edge on the inside of the panel (Fig. 6-4).

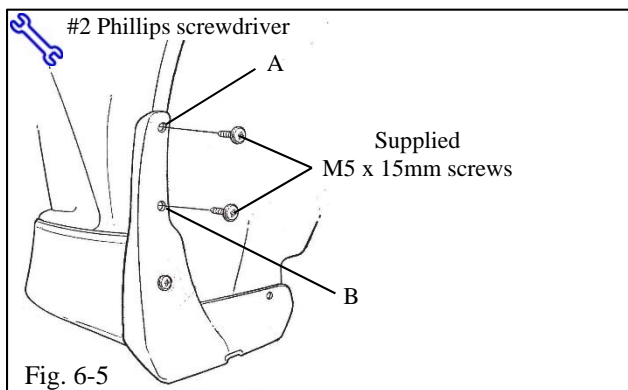

- (f) Hold the top of the mudguard firmly into the panel and install supplied 15mm screws in locations A and B, then tighten (Fig. 6-5).

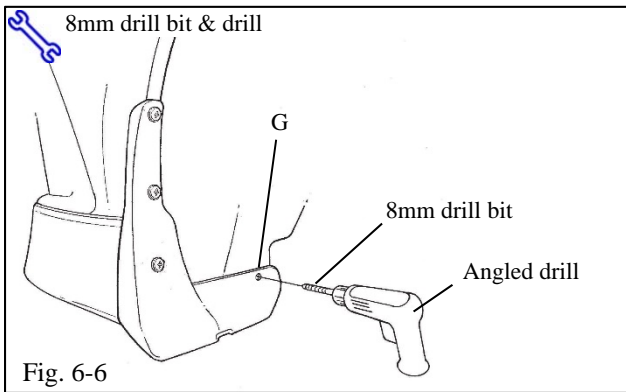

- (g) Hold the mudguard tight to the liner and use the part as a template to drill an 8mm hole in location G (Fig. 6-6).

⚠ NOTE: Use an angled drill.

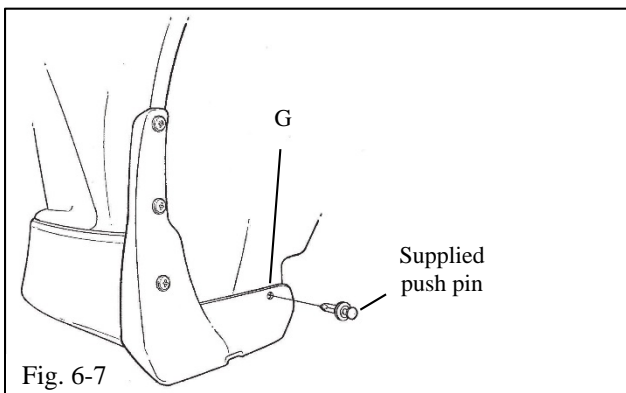

- (h) Install supplied push pin in location G while holding mudguard tight to liner. (Fig. 6-7).
- (i) Reinstall the rear wheel. Follow the owner's manual procedure.
- (j) Repeat Steps 5 & 6 on the other side.

Checklist - these points **MUST** be checked to ensure a quality installation.

<u>Check:</u>	<u>Look For:</u>
<p><u>Accessory Function Checks</u></p> <ul style="list-style-type: none"> <input type="checkbox"/> Gaps between mudguards and body side <input type="checkbox"/> <input type="checkbox"/> <input type="checkbox"/> 	<p>Gaps greater than 1.0 mm</p>
<p><u>Vehicle Function Checks</u></p> <ul style="list-style-type: none"> <input type="checkbox"/> <input type="checkbox"/> <input type="checkbox"/> 	
<p><u>Vehicle Appearance Check</u></p> <ul style="list-style-type: none"> <input type="checkbox"/> After accessory installation and removal of protective cover(s), perform a visual inspection. 	<p>Ensure no damage (including scuffs and scratches) was caused during the installation process. (For PPO installations, refer to TMS Accessory Quality Shipping Standard.)</p>